

ELS 263

Technical data

FEATURES

- ▶ Simplest assembly (snap in)
- ▶ Integrated controller
- ▶ PNP or NPN output, light or dark switching available
- ▶ Also reliable for outside applications
- ▶ Microprocessor control
- ▶ First-class electromagnetic compatibility



OPTICAL

Operating range	0.5 ... 6 m
Aperture angle	
- Emitter	±5° at 3 m
- Receiver	±20° at 3 m
Max. ambient light	100,000 Lux

MECHANICAL

Enclosure rating	IP67
Temperature range	-20°C ... +60°C

ELECTRICAL

Supply voltage U _{sp}	10 ... 30 VDC
Current consumption	
- Emitter	< 12 mA at 20 VDC
- Receiver	< 10 mA at 20 VDC
Output	PNP/NPN
Max. output current	200 mA (short circuit proof)
Max. saturation voltage at output	2.5 V
Rise time - Receiver	20 ms
Fall time - Receiver	20 ms

GENERAL

EMC emission	EN 61000-6-3:2007+A1:2011
EMC immunity	EN 61000-6-2:2005
Vibration	IEC 60068-2-6:2007
Shock	IEC 60068-2-27:2008
RoHS	2011/65/EU
Certificate	CE

CONNECTION CABLE AND ELECTRICAL CONNECTION

Cable length (cable or plug)	5 / 10 / 20 m
Diameter	Ø 3.5 mm
Jacket color	
- Emitter	Black
- Receiver	Gray

Emitter - wires	2 × 0.14 mm ² , AWG26
• brown	U _{sp}
• blue	GND (0 V)

Receiver - wires	3 × 0.14 mm ² , AWG26
• brown	U _{sp}
• blue	GND (0 V)
• black	Output



CEDES AG is certified according to ISO 9001: 2015.

Dimensions

All dimensions in mm - Emitter and Receiver have identical housing
 Proportions not to scale

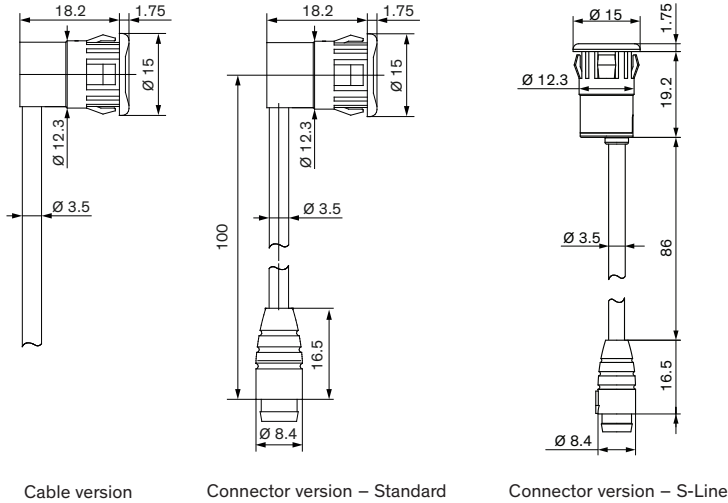
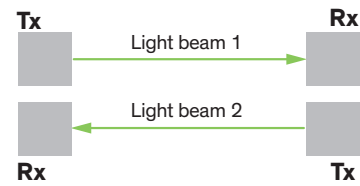

Plate thickness (mm)	Mounting hole (mm)		
	Ø 12.5	Ø 13.0	Ø 13.5
1.25	✓	✗	✗
1.50	✓	✓	✗
2.00	✓	✓	✓
2.50	✗	✓	✓

✓ = good ✗ = insufficient



When using two through beam light barriers, pay attention to crossed mounting.

Connections

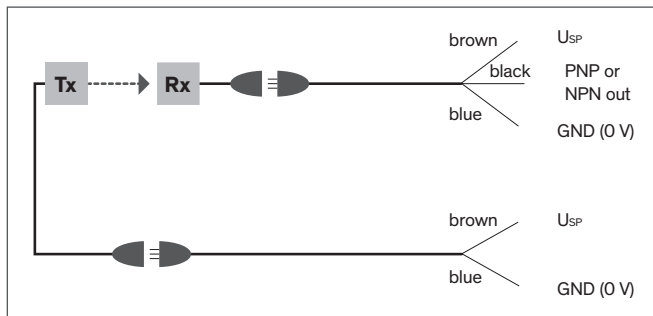

Connections with Y-switch

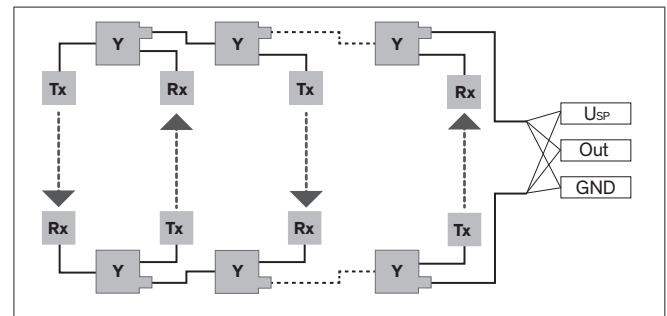

Timing diagram

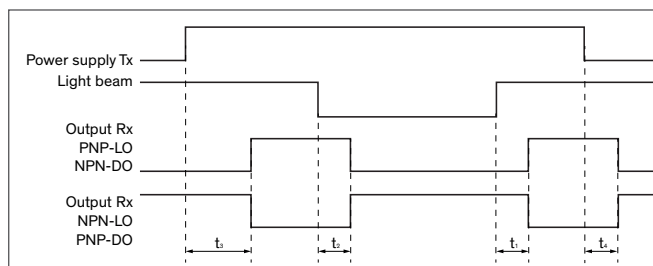

LO = Light on
 Light beam not interrupted
 → LED on

DO = Dark on
 Light beam is interrupted
 → LED on

	Time	Value
Rise time	t_1	20 ms
Fall time	t_2	20 ms
Turn-on time	t_3	≤ 80 ms
Turn-off time	t_4	≤ 27 ms

Application



Sliding doors